

# Carter Cryogenic Products Division



## Product Catalog

- ▶ Home
- ▶ **Products**
- ▶ Services
- ▶ Contact Us
- ▶ About Us
- ▶ Legal Information
- ▶ Quality
- ▶ Quality Procedures

See Related Pages on:

## [Cryogenic Product Catalog](#)

### Technical Description Features Applications

#### 2. Removable Type

#### In-Tank Submerged Motor Pumps

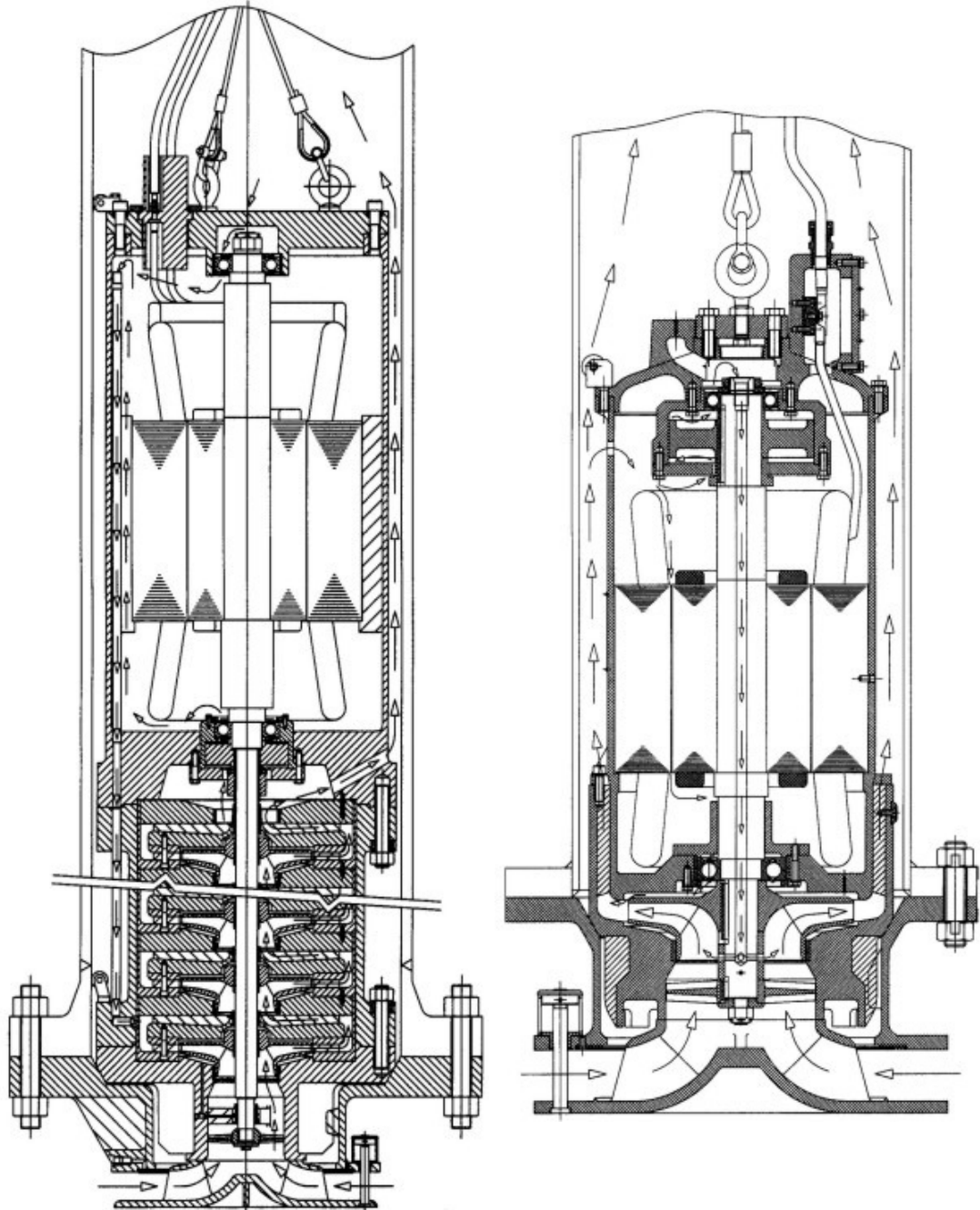

#### Description

Carter provides a patented removable pumping system that is accepted as the standard of the industry for in-tank pump installations. This system permits removal of product over the top of the tank and eliminates the need for bottom or side tank penetrations below the liquid level. Carter's concept incorporates a submerged pump that can be safely removed from a full or empty tank, even when the tank contains a boiling liquid, whose vapors are potentially hazardous. The Carter removable pumping system is available in single or multi-stage configurations.

**Other 2. Removable Type**

**[Home](#) | [Employment](#) | [Contact Us](#) | [Locations](#)**